

# LT20JE

## Telescopic Boom Lifts-Electric



### Safe and Reliable

- Standard dual channel sensor, safe and reliable;
- Electric emergency power systems provide more security;
- The protection level of components of the whole machine is above IP65, the protection level is high.

### Intelligent and efficient

- Composite action, intelligent and efficient;
- Electronic differential combined with suspending axle technology for better trafficability;
- The turntable rotates 360 ° continuously with small tail, which is suitable for narrow space operation;
- Four wheel strong AC electric drive, climbing capacity up to 45%, strong trafficability;
- High power charger and large capacity power battery can easily charge for 8 hours and work for more than 3 days.

### Energy saving and comfort

- Self -weight decrease through the booms, energy saving and stable;
- Automatic deceleration at the action limit position, stable action, small shaking;
- Optimize the electric control algorithm with the load sensitive hydraulic system to achieve accurate power output.

### Green and environmental protection

- Pure electric power, low use and maintenance cost, high return on investment;
- Green and environmental protection, no emission, low noise, meet indoor and outdoor working conditions.

### Standard configuration

- |   |                                    |
|---|------------------------------------|
| ·Platform work lights                   | ·Electric emergency descent system |
| ·Working strobe lamp                    | ·Manual emergency descent system   |
| ·Load Sensing System                    | ·Emergency stop system             |
| ·Electro hydraulic proportional control | ·Anti crash device                 |
| ·Automatic brake system                 | ·Remote fault diagnosis system     |
| ·Tilt protection system                 | ·overload protection               |
| ·Telematics-BOX                         | ·Full action warning               |



# LT20JE >>>



## Main Parameters

Item	Unit	LT20JE
<b>Size</b>		
Max.Working Height	m	21.5
Max.Platform Height	m	19.5
Max.Operating Range	m	13.4
A-Overall Length(Stowed)	m	10.2
B-Overall Width(Stowed)	m	2.42
C-Overall Height(Stowed)	m	2.75
Overall Length(Transport)	m	10.2
Overall Width(Transport)	m	2.29
Overall Height(Transport)	m	2.67
Platform Size(LxWxH)	m	1.83x0.76x1.1
Turntable Tailswing	m	1.55
D-Ground learance	m	0.31
E-Wheelbase	m	2.5
Turning Radius(Inside/Outside)	m	2.4/5.5
Tyres	/	33x12-20 (Solid tyre)
<b>Performance</b>		
Platform Load(Unrestricted)	kg	320
Max.Occupants	/	2
Gradeability	/	45%
Travel Speed(Stowed)	km/h	5
Travel Speed(Raised)	km/h	1
Max.Working Slope	/	X-5°/Y-5°
Turret Rotation	/	360°Continuous
Platform Rotation	/	±90°
Jib Movement	/	-65°~+70°
Drive Steering Type	/	4WDx2WS
<b>Weight</b>		
Overall Weight	kg	9500
<b>Power</b>		
Battery (Lithium)	/	48V/460Ah
Charger	/	48V/60A
Driving Motor	/	32VAC/3.3kW
Lifting Motor	/	31VAC/10kW
Hydraulic Tank	L	93

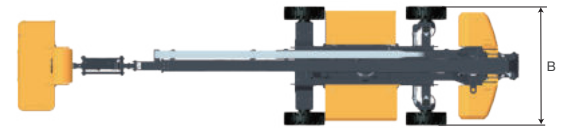
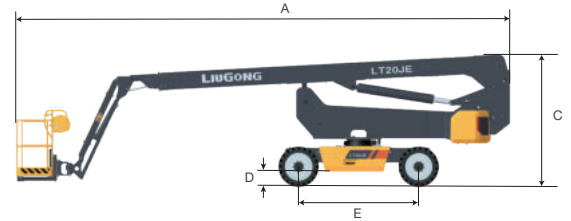

Unit: m

LT20JE Performance Curve

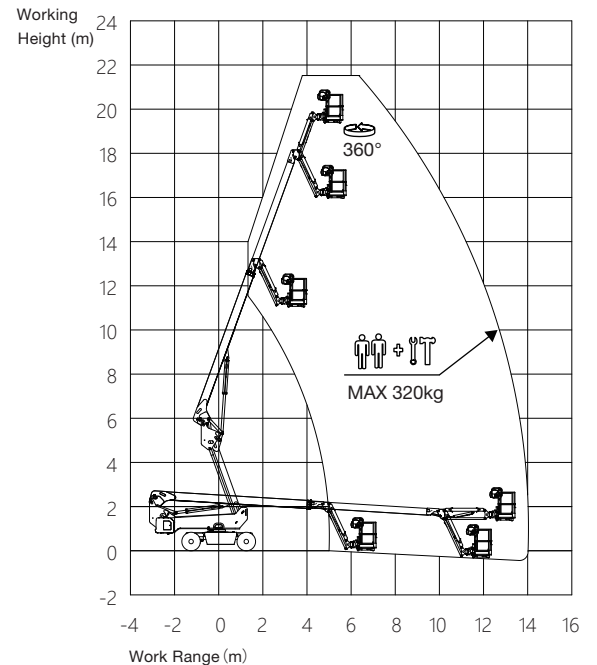

# LA20JE

## Articulating Boom Lifts-Electric



### Safe and Reliable

- Standard dual channel sensor, safe and reliable;
- Electric emergency power systems provide more security;
- The protection level of components of the whole machine is above IP65, the protection level is high.

### Intelligent and efficient

- Composite action, intelligent and efficient;
- Electronic differential combined with suspending axle technology for better trafficability;
- The turntable rotates 360 ° continuously with small tail, which is suitable for narrow space operation;
- Four wheel strong AC electric drive, climbing capacity up to 45%, strong trafficability;
- High power charger and large capacity power battery can easily charge for 8 hours and work for more than 3 days.

### Energy saving and comfort

- Self -weight decrease through the booms, energy saving and stable;
- Automatic deceleration at the action limit position, stable action, small shaking;
- Optimize the electric control algorithm with the load sensitive hydraulic system to achieve accurate power output.

### Green and environmental protection

- Pure electric power, low use and maintenance cost, high return on investment;
- Green and environmental protection, no emission, low noise, meet indoor and outdoor working conditions.

### Standard configuration

- Platform work lights
- Working strobe lamp
- Load Sensing System
- Electro hydraulic proportional control
- Automatic brake system
- Tilt protection system
- Telematics-BOX
- Electric emergency descent system
- Manual emergency descent system
- Emergency stop system
- Anti crash device
- Remote fault diagnosis system
- overload protection
- Full action warning



# LA20JE >>>



## Main Parameters

Item	Unit	LA20JE
<b>Size</b>		
Max.Working Height	m	22.2
Max.Platform Height	m	20.2
Max.Operating Range	m	12.6
A-Overall Length(Stowed)	m	8.87
B-Overall Width(Stowed)	m	2.42
C-Overall Height(Stowed)	m	2.32
Overall Length(Transport)	m	8.87
Overall Width(Transport)	m	2.29
Overall Height(Transport)	m	2.2
Platform Size(L×W×H)	m	1.8×0.76×1.1
Turntable Tailswing	m	0.72
D-Ground learance	m	0.31
E-Wheelbase	m	2.5
Turning Radius(Inside/Outside)	m	2.4/5.5
Tyres	/	33×12-20 (Solid tyre)
Maximum crossing height	m	8.3
<b>Performance</b>		
Platform Load(Unrestricted)	kg	260
Max.Occupants	/	2
Gradeability	/	45%
Travel Speed(Stowed)	km/h	5
Travel Speed(Raised)	km/h	0.6
Max.Working Slope	/	X-5°/Y-5°
Turret Rotation	/	360°Continuous
Platform Rotation	/	±90°
Jib Movement	/	-65°~+70°
Drive Steering Type	/	4WD×2WS
<b>Weight</b>		
Overall Weight	kg	9650
<b>Power</b>		
Battery (Lithium)	/	48V/460Ah
Charger	/	48V/60A
Driving Motor	/	32VAC/3.3kW
Lifting Motor	/	32VAC/10kW
Hydraulic Tank	L	93

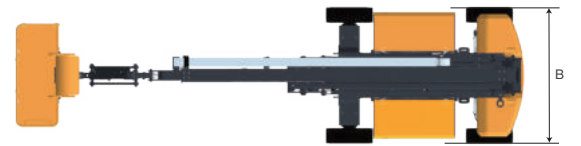
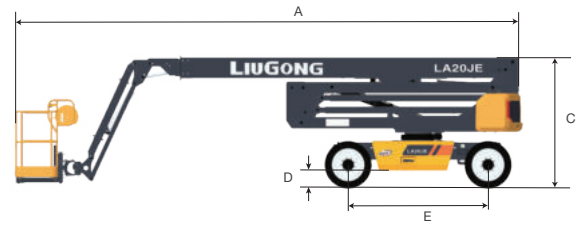

Unit: m

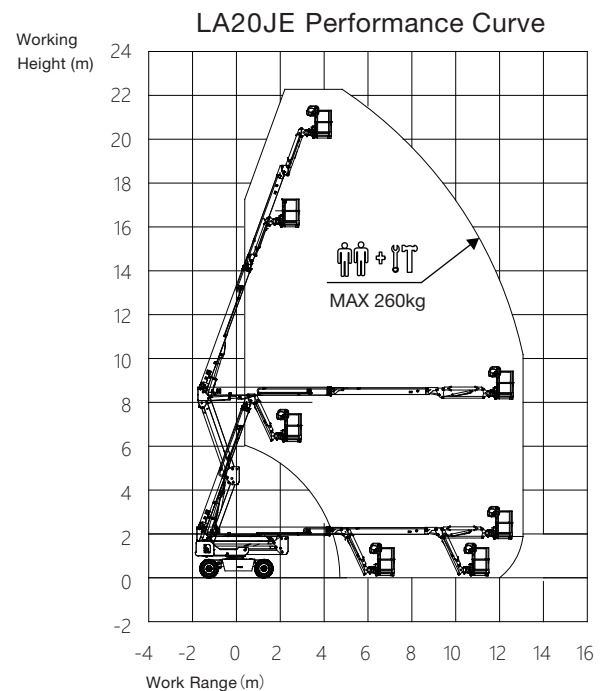

# LT26JE

## Telescopic Boom Lifts-Electric



### Safe and Reliable

- Standard dual channel sensor, safe and reliable;
- Electric emergency power systems provide more security;
- The protection level of components of the whole machine is above IP65, the protection level is high.

### Intelligent and efficient

- Composite action, intelligent and efficient;
- Electronic differential combined with suspending axle technology for better trafficability;
- The turntable rotates 360 ° continuously with small tail, which is suitable for narrow space operation;
- Four wheel strong AC electric drive, climbing capacity up to 45%, strong trafficability;
- High power charger and large capacity power battery can easily charge for 8 hours and work for more than 3 days.

### Energy saving and comfort

- Self -weight decrease through the booms, energy saving and stable;
- Automatic deceleration at the action limit position, stable action, small shaking;
- Optimize the electric control algorithm with the load sensitive hydraulic system to achieve accurate power output.

### Green and environmental protection

- Pure electric power, low use and maintenance cost, high return on investment;
- Green and environmental protection, no emission, low noise, meet indoor and outdoor working conditions.

### Standard configuration

- Platform work lights
- Working strobe lamp
- Load Sensing System
- Electro hydraulic proportional control
- Automatic brake system
- Tilt protection system
- Telematics-BOX
- Electric emergency descent system
- Manual emergency descent system
- Emergency stop system
- Anti crash device
- Remote fault diagnosis system
- overload protection
- Full action warning



# LT26JE >>>



## Main Parameters

Item	Unit	LT26JE
<b>Size</b>		
Max.Working Height	m	28
Max.Platform Height	m	26
Max.Operating Range	m	19.28
A-Overall Length(Stowed)	m	11.03
B-Overall Width(Stowed)	m	2.44
C-Overall Height(Stowed)	m	2.88
Overall Length(Transport)	m	11.31
Overall Width(Transport)	m	2.28
Overall Height(Transport)	m	2.68
Platform Size(LxWxH)	m	2.44x0.91x1.1
Turntable Tailswing	m	1.62
D-Ground learance	m	0.29
E-Wheelbase	m	3
Turning Radius(Inside/Outside)	m	3.5/6.8
Tyres	/	385/65-24 (Solid tyre)
<b>Performance</b>		
Platform Load(Unrestricted)	kg	320
Max.Occupants	/	2
Gradeability	/	45%
Travel Speed(Stowed)	km/h	5
Travel Speed(Raised)	km/h	1
Max.Working Slope	/	X-5°/Y-5°
Turret Rotation	/	360°Continuous
Platform Rotation	/	±90°
Jib Movement	/	-65°~+70°
Drive Steering Type	/	4WDx2WS
<b>Weight</b>		
Overall Weight	kg	15000
<b>Power</b>		
Battery (Lithium)	/	80V/460Ah
Charger	/	80V/80A
Driving Motor	/	52VAC/5.2kW
Lifting Motor	/	52VAC/30kW
Hydraulic Tank	L	140

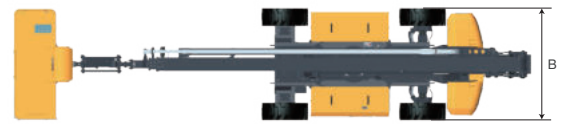
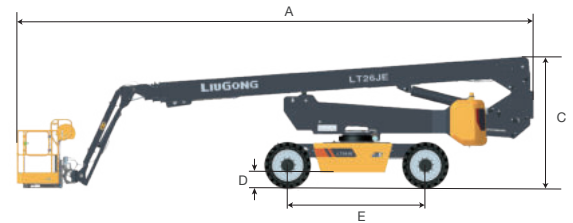

Unit: m

LT26JE Performance Curve

